

UNITS 1-6

Guided Phonics + Beyond

INSTANT *assessments*



©Tara West

©Tara West Little Minds at Work

Thanks so much for downloading the free Guided Phonics + Beyond supplemental packet: INSTANT Assessments. Please view this explicit and thorough explanation video for the [HERE](#) and [HERE](#). The Guided Phonics + Beyond Curriculum includes 275 days of explicit and systematic lesson plans, decodable books, embedded high frequency words, phonemic awareness, and more. View the comprehensive and science of reading aligned curriculum, Guided Phonics + Beyond, [HERE](#). Within this packet you will be able to access the following end of the year assessments:

- **UNIT 1:** ABCs
- **UNIT 2:** CVC words
- **UNIT 3:** Digraphs, double endings, and beginning blends
- **UNIT 4:** CVCE words
- **UNIT 5:** Ending blends, r-controlled vowels, and silent letters
- **UNIT 6:** Vowel variants

If you have any additional questions, feel free join the [Facebook Community](#), email me at littlemindsatworkLLC@gmail.com, or visit my blog, [Little Minds at Work](#).

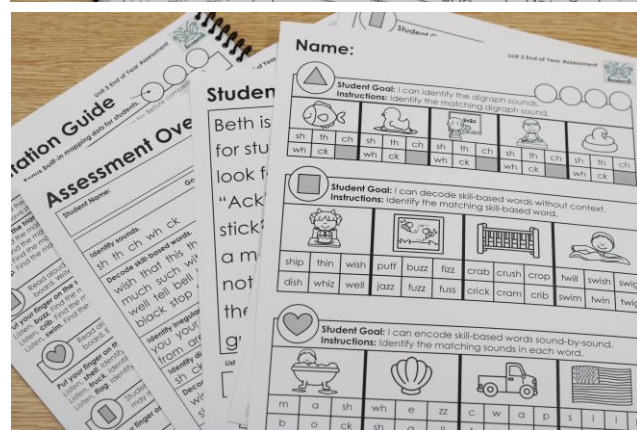
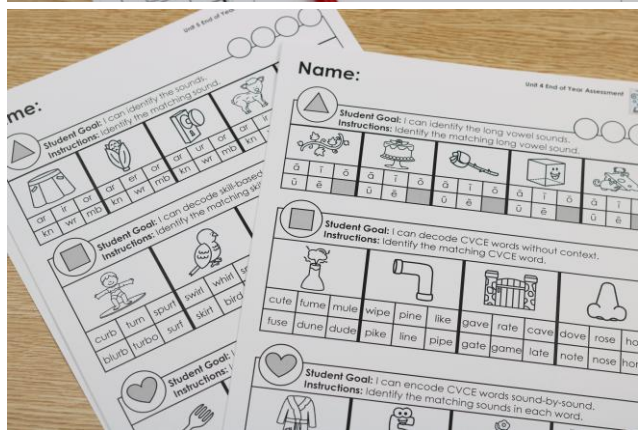
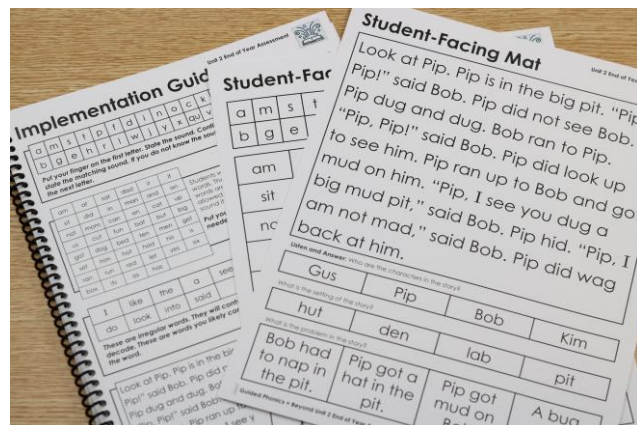
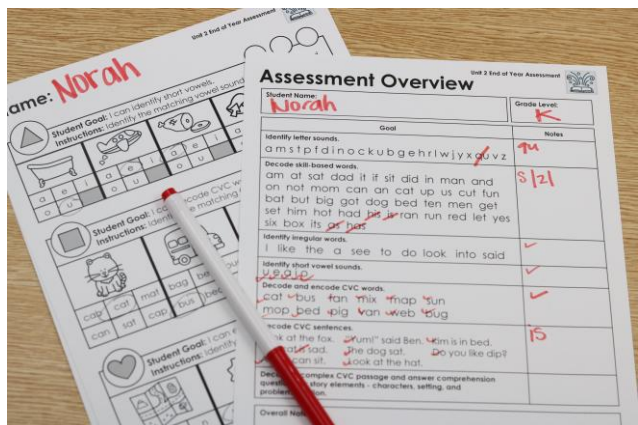
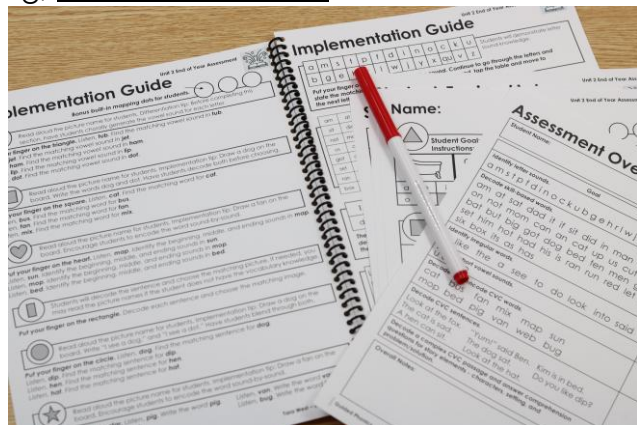
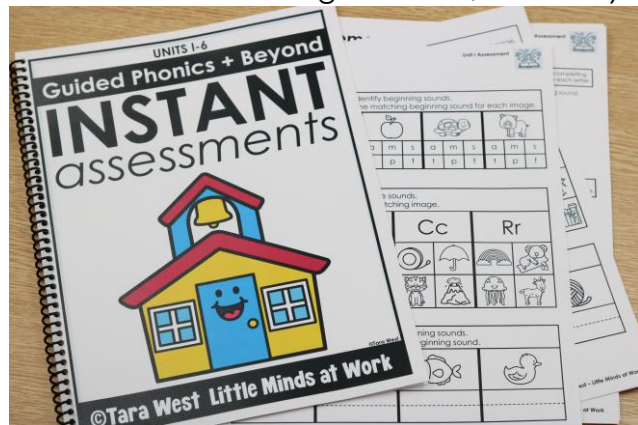

UNIT I

Assessment



Name: _____

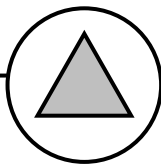

Student Goal: I can identify beginning sounds.

Instructions: Identify the matching beginning sound for each image.

a	m	s	a	m	s	a	m	s	a	m	s	a	m	s
t	p	f	t	p	f	t	p	f	t	p	f	t	p	f

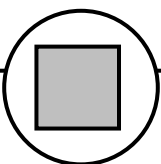

Student Goal: I can decode sounds.

Instructions: Identify the matching image.

Bb		Ll		Cc		Rr	

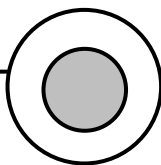

Student Goal: I can encode beginning sounds.

Instructions: Write the matching beginning sound.

_____	_____	_____	_____

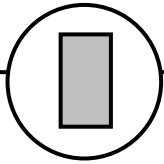

Student Goal: I can identify beginning sounds.

Instructions: Identify the matching beginning sound for each image.

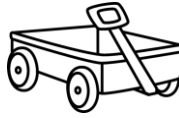

i g k

i g k

i g k

i g k

i g k

w j u

w j u

w j u

w j u

w j u

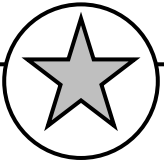

Student Goal: I can decode sounds.

Instructions: Identify the matching image.

Kk

Vv

Hh

Xx

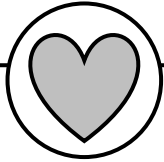
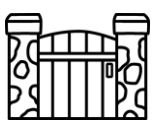
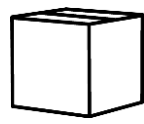
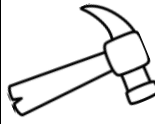
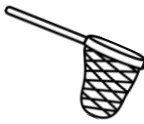

Student Goal: I can encode beginning sounds.

Instructions: Write the matching beginning sound.



Blank writing area with a dashed line for handwriting practice.



Student-Facing Mat

a	m	s	t	p	f	d	i	n	o	c	k	u
b	g	e	h	r	l	w	j	y	x	qu	v	z

g	T	D	P	r	b
Z	c	S	a	h	m
t	n	H	L	U	e
y	E	O	F	C	X
z	G	K	V	Q	j
p	s	o	i	R	q
l	k	w	B	f	A
J	W	d	M	U	Y
v	N	I	X		



Implementation Guide

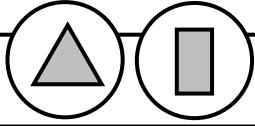

Read aloud the picture name for students. Differentiation tip: Before completing this section, have students chorally generate the beginning sound for each letter.

Put your finger on the triangle/rectangle. Listen, **monkey**. Find the matching beginning sound.

Listen, **sun**. Find the matching beginning sound in **sun**.

Listen, **apple**. Find the matching beginning sound in **apple**.

Listen, **turtle**. Find the matching beginning sound in **turtle**.

Listen, **pig**. Find the matching beginning sound in **pig**.

Listen, **juggle**. Find the matching beginning sound in **juggle**.

Listen, **itch**. Find the matching beginning sound in **itch**.

Listen, **wagon**. Find the matching beginning sound in **wagon**.

Listen, **goat**. Find the matching beginning sound in **goat**.

Listen, **umbrella**. Find the matching beginning sound in **umbrella**.

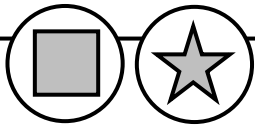

Read aloud the picture name for students. Differentiation tip: Before completing this section, have students chorally generate the beginning sound for each image.

Put your finger on the square/star. Generate the letter's matching beginning sound. Find the image with the matching beginning sound.

Bb: pizza, **bear**, wagon, nail

Ll: zebra, igloo, hammer, **lion**

Cc: yo-yo, umbrella, **cat**, volcano

Rr: **rainbow**, koala, jellyfish, goat

Kk: apple, leaf, dinosaur, **king**

Vv: net, moon, **volcano**, pumpkin

Hh: **hammer**, bug, fish, carrot

Xx: **box**, walrus, hat, gate

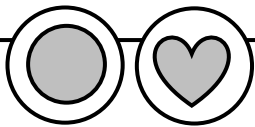

Read aloud the picture name for students. Differentiation tip: Before completing this section, have students chorally generate the beginning sound for each image.

Put your finger on the circle/heart. Listen, **octopus**. Write the matching beginning sound letter.

Listen, **nest**. Write the matching beginning sound in **nest**.

Listen, **fish**. Write the matching beginning sound in **fish**.

Listen, **duck**. Write the matching beginning sound in **duck**.

Listen, **zipper**. Write the matching beginning sound in **zipper**.

Listen, **queen**. Write the matching beginning sound in **queen**.

Listen, **edge**. Write the matching beginning sound in **edge**.

Listen, **yarn**. Write the matching beginning sound in **yarn**.



Implementation Guide

a	m	s	t	p	f	d	i	n	o	c	k	u
b	g	e	h	r	l	w	j	y	x	qu	v	z

Students will demonstrate letter sound knowledge.

Put your finger on the first letter. State the sound. Continue to go through the letters and state the matching sound. If you do not know the sound, tap the table and move to the next letter.

g	T	D	P	r	b
Z	c	S	a	h	m
t	n	H	L	U	e
y	E	O	F	C	X
z	G	K	V	Q	j
p	s	o	i	R	q
l	k	w	B	f	A
J	W	d	M	u	Y
v	N	I	x		

Students will display their ability to identify letter names for both lowercase letters and capital letters.

Put your finger on the first letter. Tell me the letter name.



Assessment Overview

Student Name:	Grade Level:
Goal	Notes
<p>Identify letter sounds.</p> <p>a m s t p f d i n o c k u b g e h r l w j y x q u v z</p>	
<p>Identify letter names.</p> <p>A a B b C c D d E e F f G g H h I i</p> <p>J j K k L l M m N n O o P p Q q R r</p> <p>S s T t U u V v W w X x Y y Z z</p>	
<p>Generate beginning sounds.</p> <p>Mm Ss Aa Tt Pp Jj Ii Ww Gg Uu</p>	
<p>Connect sounds to images.</p> <p>Bb Ll Cc Rr Kk Vv Hh <u>Xx</u></p>	
<p>Write matching beginning sounds.</p> <p>Oo Nn Ff Dd Zz Qq Ee Yy</p>	

Overall Notes:

Phonics Skills At-Home Support Guide

This guide provides simple ways to support your child's early phonics skills at home. The activities are designed to be quick, hands-on, and easy to use with everyday materials. Practicing these skills regularly will help build confidence, strengthen letter and sound knowledge, and support your child's success as they continue learning to read and write.

Identify letter sounds.

- Point to letters in books or signs and say the sound
- Watch how the mouth moves when making each sound
- Play "What sound is this?" with magnetic or foam letters
- Match letters to objects that begin with the same sound

Identify letter names.

- Sing the alphabet song together
- Use flashcards to practice naming letters
- Find letters during daily routines (cereal boxes, signs, books)
- Mix up letter cards and name them quickly

Generate beginning sounds.

- Ask, "What sound do you hear at the beginning of sun?"
- Sort objects by beginning sound
- Play beginning sound games during car rides or meals
- Say a word and have your child tell the first sound

Connect sounds to images.

- Match pictures to the correct beginning sound
- Look through magazines and name picture sounds
- Use picture cards and sort by first sound
- Ask your child to find items around the house that match a sound

Write matching beginning sounds.

- Say a word and write the first letter together
- Practice writing letters while saying the sound aloud
- Label simple drawings with beginning sounds
- Use crayons, markers, or shaving cream to practice letter writing

Identify and produce rhyming words.

- Read rhyming books and pause to say the rhyming word
- Play "Do these words rhyme?" with simple word pairs
- Say a word and think of another word that rhymes
- Sing songs together to hear repeated word patterns



UNIT 2

Assessment



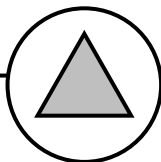

Name: _____

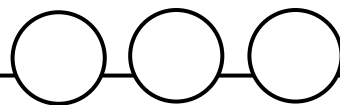

Student Goal: I can identify short vowels.

Instructions: Identify the matching vowel sound in each CVC word.

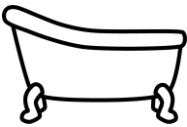
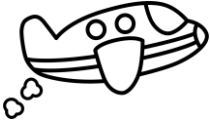
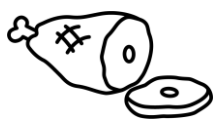

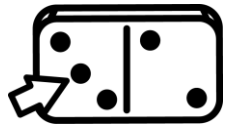

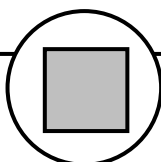
														
a	e	i	a	e	i	a	e	i	a	e	i	a	e	i
o	u		o	u		o	u		o	u		o	u	



Student Goal: I can decode CVC words without context.

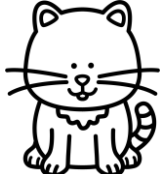
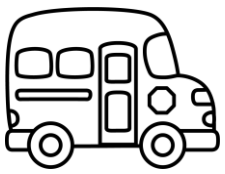

Instructions: Identify the matching CVC word.

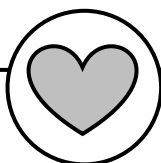
											
cab	cat	mat	bag	beg	bug	man	fig	fan	net	six	mat
can	sat	cap	bus	bed	bad	fin	can	fog	mix	map	box



Student Goal: I can encode CVC words sound-by-sound.

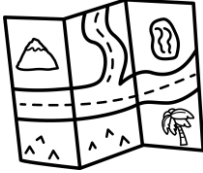
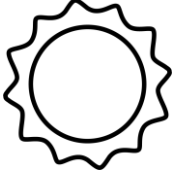



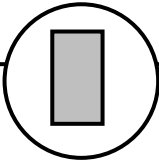



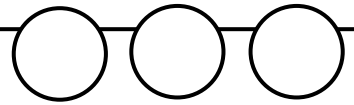







Instructions: Identify the matching sounds in each word.

											
t	u	n	s	e	n	t	u	n	s	e	n
s	a	p	m	u	d	s	a	p	m	u	d
m	o	t	b	o	t	m	o	t	b	o	t







Student Goal: I can decode simple context.
Instructions: Identify the matching image.

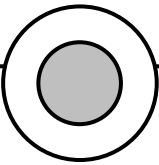

Look at the fox.		"Yum!" said Ben.		Kim is in bed.		The cat is sad.	
							
							



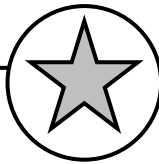

Student Goal: I can decode CVC words in context.
Instructions: Identify the matching sentence.

			
The cat sat.	Do you like dip?	Look at him hug.	The cat can run.
Look at the fox.	I got a big box.	The cab is big.	Look at the hat.
The dog sat.	The pig can nap.	A hen can sit.	A mom can zip it.

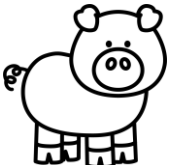
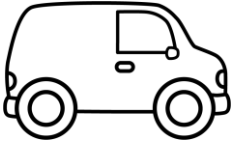

Student Goal: I can encode CVC words sound-by-sound.
Instructions: Write the matching word sound-by-sound.

			
-----	-----	-----	-----



Student-Facing Mat

a	m	s	t	p	f	d	i	n	o	c	k	u
b	g	e	h	r	l	w	j	y	x	qu	v	z

am	at	sat	dad	it	if
sit	did	in	man	and	on
not	mom	can	an	cat	up
us	cut	fun	bat	but	big
got	dog	bed	ten	men	get
set	him	hot	had	his	is
ran	run	red	let	yes	six
box	its	as	has		

I	like	the	a	see	to
do	look	into	said		

Student-Facing Mat

Look at Pip. Pip is in the big pit. “Pip, Pip!” said Bob. Pip did not see Bob. Pip dug and dug. Bob ran to Pip. “Pip, Pip!” said Bob. Pip did look up to see him. Pip ran up to Bob and got mud on him. “Pip, I see you dug a big mud pit,” said Bob. Pip hid. “Pip, I am not mad,” said Bob. Pip did wag back at him.

Listen and Answer: Who are the characters in the story?

Gus

Pip

Bob

Kim

What is the setting of the story?

hut

den

lab

pit

What is the problem in the story?

Bob had to nap in the pit.

Pip got a hat in the pit.

Pip got mud on Bob.

A bug got on Pip.



Implementation Guide

Bonus built-in mapping dots for students.

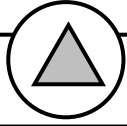

Read aloud the picture name for students. Differentiation tip: Before completing this section, have students chorally generate the vowel sound for each letter.

Put your finger on the triangle. Listen, **tub**. Find the matching vowel sound in **tub**.

Listen, **jet**. Find the matching vowel sound in **jet**.

Listen, **ham**. Find the matching vowel sound in **ham**.

Listen, **lip**. Find the matching vowel sound in **lip**.

Listen, **dot**. Find the matching vowel sound in **dot**.

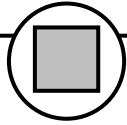

Read aloud the picture name for students. Implementation tip: Draw a dog on the board. Write the words dog and dot. Have students decode both before choosing.

Put your finger on the square. Listen, **cat**. Find the matching word for **cat**.

Listen, **bus**. Find the matching word for **bus**.

Listen, **fan**. Find the matching word for **fan**.

Listen, **mix**. Find the matching word for **mix**.



Read aloud the picture name for students. Implementation tip: Draw a fan on the board. Encourage students to encode the word sound-by-sound.

Put your finger on the heart. Listen, **map**. Identify the beginning, middle, and ending sounds in **map**.

Listen, **sun**. Identify the beginning, middle, and ending sounds in **sun**.

Listen, **mop**. Identify the beginning, middle, and ending sounds in **mop**.

Listen, **bed**. Identify the beginning, middle, and ending sounds in **bed**.

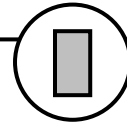

Students will decode the sentence and choose the matching picture. If needed, you may read the picture names if the student does not have the vocabulary knowledge.

Put your finger on the rectangle. Decode each sentence and choose the matching image.

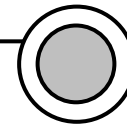

Read aloud the picture name for students. Implementation tip: Draw a dog on the board. Write "I see a dog." and "I see a dot." Have students blend through both.

Put your finger on the circle. Listen, **dog**. Find the matching sentence for **dog**.

Listen, **dip**. Find the matching sentence for **dip**.

Listen, **hen**. Find the matching sentence for **hen**.

Listen, **hat**. Find the matching sentence for **hat**.

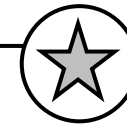

Read aloud the picture name for students. Implementation tip: Draw a fan on the board. Encourage students to encode the word sound-by-sound.

Put your finger on the star. Listen, **pig**. Write the word **pig**.

Listen, **web**. Write the word **web**.

Listen, **van**. Write the word **van**.

Listen, **bug**. Write the word **bug**.



Implementation Guide

a	m	s	t	p	f	d	i	n	o	c	k	u
b	g	e	h	r	l	w	j	y	x	qu	v	z

Students will demonstrate letter sound knowledge.

Put your finger on the first letter. State the sound. Continue to go through the letters and state the matching sound. If you do not know the sound, tap the table and move to the next letter.

am	at	sat	dad	it	if
sit	did	in	man	and	on
not	mom	can	an	cat	up
us	cut	fun	bat	but	big
got	dog	bed	ten	men	get
set	him	hot	had	his	is
ran	run	red	let	yes	six
box	its	as	has		

Students will display their ability to decode skill-based words. These *are* high frequency words. However, these words are decodable, and students are allowed/encouraged to decode the words sound-by-sound if needed.

Put your finger on the first word. Read the word. If needed, stretch the word sound-by sound.

I	like	the	a	see	to
do	look	into	said		

Students will demonstrate irregular word knowledge.

These are irregular words. They will contain irregular or heart sounds that you cannot fully decode. These are words you likely can tell me by sight. Put your finger on the first word. State the word.

Look at Pip. Pip is in the big pit. "Pip, Pip!" said Bob. Pip did not see Bob. Pip dug and dug. Bob ran to Pip. "Pip, Pip!" said Bob. Pip did look up to see him. Pip ran up to Bob and got mud on him. "Pip, I see you dug a big mud pit," said Bob. Pip hid. "Pip, I am not mad," said Bob. Pip did wag back at him.

Students will display their ability to decode a complex skill-based passage. After reading, students will be asked to display their reading comprehension of the passage.

Read the passage to discover the characters, setting, and problem of the story.

Students will identify the comprehension story elements from the passage.

Characters (**Pip and Bob**)

Setting (**pit**)

Problem (**Pip got mud on Bob.**)



Assessment Overview

Student Name:	Grade Level:
Goal	Notes
Identify letter sounds. a m s t p f d i n o c k u b g e h r l w j y x q u v z	
Decode skill-based words. am at sat dad it if sit did in man and on not mom can an cat up us cut fun bat but big got dog bed ten men get set him hot had his is ran run red let yes six box its as has	
Identify irregular words. I like the a see to do look into said	
Identify short vowel sounds. u e a i o	
Decode and encode CVC words. cat bus fan mix map sun mop bed pig van web bug	
Decode CVC sentences. Look at the fox. "Yum!" said Ben. Kim is in bed. The cat is sad. The dog sat. Do you like dip? A hen can sit. Look at the hat.	
Decode a complex CVC passage and answer comprehension questions for story elements - characters, setting, and problem/solution.	

Overall Notes:

Phonics Skills At-Home Support Guide

This guide provides simple ways to support your child's early reading and CVC phonics skills at home. The activities are designed to be quick, hands-on, and easy to use with everyday materials. Practicing these CVC skills regularly will help build confidence, strengthen decoding skills, and support your child's success as they continue learning to read.

Identify letter sounds.

- Practice saying individual letter sounds such as /m/, /s/, and /t/
- Watch how the mouth moves when making sounds and connect the sounds to simple CVC words such as mat, sat, and tap

Decode skill-based words.

- Tap and blend CVC words such as cat, dog, and sun while reading aloud
- Use magnetic letters to build and read CVC words such as pig, bed, and lip

Identify irregular words.

- Practice reading irregular words commonly found in CVC sentences such as the, said, to, and do
- Find irregular words while reading simple CVC books together

Identify short vowel sounds.

- Sort CVC words by vowel sound such as cat, map, and bag for short a
- Stretch CVC words aloud to hear the middle vowel sound in words such as pig, hop, and tub

Decode and encode CVC words.

- Read CVC words by sounding out each letter in words such as jam, pen, and fox. Tap each letter as you blend: /s/, /u/, /n/ and put it together: sun.
- Say a CVC word aloud, tap the sounds in the word, and then write the sounds heard in words such as rug and lid

Decode CVC sentences.

- Read short CVC sentences such as "The cat sat." and "The pig can hop."
- Reread CVC sentences to build fluency and confidence while pointing to each word

Decode and comprehend CVC passages.

- Read short CVC passages and talk about the characters, setting, and main story events
- Ask questions such as "What was the problem?" and "How was it solved?" after reading the passage



UNIT 3

Assessment



Name: _____

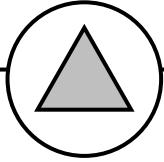

Student Goal: I can identify the digraph sounds.

Instructions: Identify the matching digraph sound.

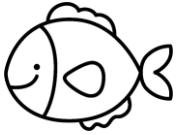

sh	th	ch	sh	th	ch	sh	th	ch	sh	th	ch	sh	th	ch
wh	ck		wh	ck		wh	ck		wh	ck		wh	ck	

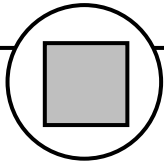

Student Goal: I can decode skill-based words without context.

Instructions: Identify the matching skill-based word.

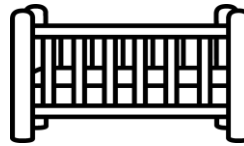
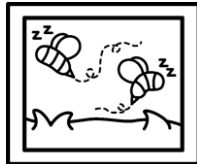

ship	thin	wish	puff	buzz	fizz	crab	crush	crop	twill	swish	swig
dish	whiz	well	jazz	fuzz	fuss	crick	cram	crib	swim	twin	twig

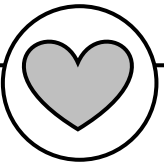

Student Goal: I can encode skill-based words sound-by-sound.

Instructions: Identify the matching sounds in each word.

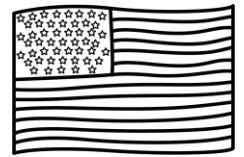
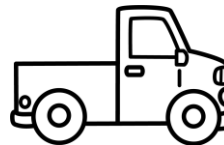



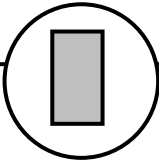



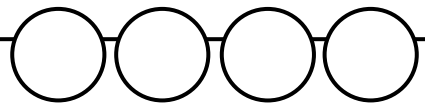







m	a	sh	wh	e	zz	c	w	a	p	s	l	i	p
b	o	ck	sh	a	ll	t	r	u	ck	t	r	a	m
s	e	th	ch	i	ss	s	l	i	m	f	w	u	g





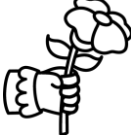

Student Goal: I can decode simple context.
Instructions: Identify the matching image.

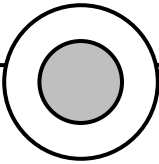

The kids chat.		Did he miss that?		She can flush it.		Will they press it?	
							
							



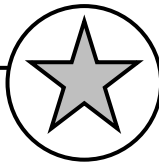

Student Goal: I can decode skill-based words in context.
Instructions: Identify the matching sentence.

			
They can fish.	Did he yell?	That is a big mess.	She will get a drill.
He has a red rash.	Go to the well.	That box has less.	The drum is big.
The net is mesh.	The bell fell.	Do you like chess?	That is her dress.

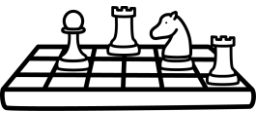
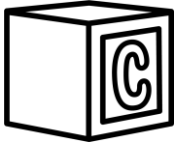

Student Goal: I can encode skill-based words sound-by-sound.
Instructions: Write the matching word sound-by-sound.



Student-Facing Mat

sh	th	ch	wh	ck	
----	----	----	----	----	--

wish	that	this	them	then	back
duck	pick	much	such	with	when
which	miss	off	will	well	tell
bell	he	be	we	me	she
go	so	no	black	stop	step
spell	spot	still			

you	your	they	was	here	what
who	all	play	from	are	for
or	of				

Student-Facing Mat

Beth is at the shed with Mom to look for stuff to fish with. Beth and Mom look for the mesh net and the rod.

“Ack! Mom! What is this on that stick?” said Beth with a shock. “That is a moth. A moth has six thin legs. Do not pick it up,” said Mom. “I will grab the stick and toss it back in the grass,” said Beth.

Listen and Answer: Who are the characters in the story?

Mom	Seth	Beth	Dad
-----	------	------	-----

What is the setting of the story?

shop	shed	hill	track
------	------	------	-------

What is the problem in the story?

Beth did not see a moth.	Mom fell in the shed.	A moth did shock Beth.	Beth hit her leg.
--------------------------	-----------------------	------------------------	-------------------



Implementation Guide

Bonus built-in mapping dots for students.

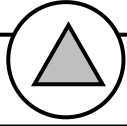

Read aloud the picture name for students. Differentiation tip: Before completing this section, have students chorally generate the digraph sounds.

Put your finger on the triangle. Listen, **fish**. Find the matching digraph in **fish**.

Listen, **duck**. Find the matching digraph in **duck**.

Listen, **math**. Find the matching digraph in **math**.

Listen, **chop**. Find the matching digraph in **chop**.

Listen, **whip**. Find the matching digraph in **whip**.

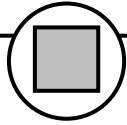

Read aloud the picture name for students. Implementation tip: Draw a shop on the board. Write the words ship and shop. Have students decode both before choosing.

Put your finger on the square. Listen, **wish**. Find the matching word for **wish**.

Listen, **buzz**. Find the matching word for **buzz**.

Listen, **crib**. Find the matching word for **crib**.

Listen, **swim**. Find the matching word for **swim**.

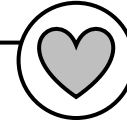

Read aloud the picture name for students. Implementation tip: Draw a path on the board. Encourage students to encode the word sound-by-sound.

Put your finger on the heart. Listen, **bath**. Identify the beginning, middle, and ending sounds in **bath**.

Listen, **shell**. Identify the sounds in **shell**.

Listen, **truck**. Identify the sounds in **truck**.

Listen, **flag**. Identify the sounds in **flag**.

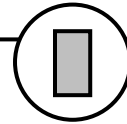

Students will decode the sentence and choose the matching picture. If needed, you may read the picture names if the student does not have the vocabulary knowledge.

Put your finger on the rectangle. Decode each sentence and choose the matching image.

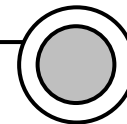

Read aloud the picture name for students. Implementation tip: Draw a moth on the board. Write "I see a moth." and "I see a bath." Have students blend through both.

Put your finger on the circle. Listen, **rash**. Find the matching sentence for **rash**.

Listen, **bell**. Find the matching sentence for **bell**.

Listen, **mess**. Find the matching sentence for **mess**.

Listen, **drill**. Find the matching sentence for **drill**.

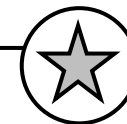

Read aloud the picture name for students. Implementation tip: Draw a truck on the board. Encourage students to encode the word sound-by-sound.

Put your finger on the star. Listen, **shot**. Write the word **shot**.

Listen, **block**. Write the word **block**.

Listen, **chess**. Write the word **chess**.

Listen, **frog**. Write the word **frog**.



Implementation Guide

sh	th	ch	wh	ck	
----	----	----	----	----	--

Students will demonstrate digraph sound knowledge.

Put your finger on the first digraph. State the sound. Continue to go through the digraphs and state the matching sound. If you do not know the sound, tap the table and move to the next digraph.

wish	that	this	them	then	back
duck	pick	much	such	with	when
which	miss	off	will	well	tell
bell	he	be	we	me	she
go	so	no	black	stop	step
spell	spot	still			

Students will display their ability to decode skill-based words. These are high frequency words. However, these words are decodable, and students are allowed/encouraged to decode the words sound-by-sound if needed.

Put your finger on the first word. Read the word. If needed, stretch the word sound-by sound.

you	your	they	was	here	what
who	all	play	from	are	for
or	of				

Students will demonstrate irregular word knowledge.

These are irregular words. They will contain irregular or heart sounds that you cannot fully decode. These are words you likely can tell me by sight. Put your finger on the first word. State the word.

Beth is at the shed with Mom to look for stuff to fish with. Beth and Mom look for the mesh net and the rod. "Ack! Mom! What is this on that stick?" said Beth with a shock. "That is a moth. A moth has six thin legs. Do not pick it up," said Mom. "I will grab the stick and toss it back in the grass," said Beth.

Students will display their ability to decode a complex skill-based passage. After reading, students will be asked to display their reading comprehension of the passage.

Read the passage to discover the characters, setting, and problem of the story.

Students will identify the comprehension story elements from the passage.

Characters **(Mom and Beth)**
 Setting **(shed)**
 Problem **(A moth did shock Beth.)**



Assessment Overview

Student Name:	Grade Level:
Goal	Notes
Identify sounds. sh th ch wh ck	
Decode skill-based words. wish that this them then back duck pick much such with when which miss off will well tell bell he be we me she go so no black stop step spell spot still	
Identify irregular words. you your they was here what who all play from are for or of	
Identify digraph sounds. sh ck th ch wh	
Decode and encode digraph, double ending and blend words. wish buzz crib swim bath shell truck flag shot chess block frog	
Decode skill-based sentences. The kids chat. Did he miss that? She can flush it. Will they press it? He has a red rash. The bell fell. That is a big mess. She will get a drill.	
Decode a complex digraphs, double endings, and beginning blends passage and answer comprehension questions for story elements - characters, setting, and problem/solution.	
Overall Notes:	

Phonics Skills At-Home Support Guide

This guide provides simple ways to support your child's early reading and digraph, CCVC, and double ending consonant phonics skills at home. The activities are designed to be quick, hands-on, and easy to use with everyday materials. Practicing these skills regularly will help build confidence, strengthen decoding skills, and support their success as they continue learning to read.

Identify sounds.

- Practice saying digraph sounds such as /sh/, /th/, /ch/, /wh/, and /ck/ when shown the letter combinations
- Watch how the mouth moves when making digraph sounds and connect the sounds to words such as ship, chop, and thin

Decode skill-based words.

- Tap and blend digraph words such as wish, bath, and duck while reading
- Read CCVC and double ending consonant words such as stop and fell

Identify irregular words.

- Practice reading irregular words in sentences such as they, was, and who
- Find irregular words while reading books together

Identify digraph sounds.

- Sort words by digraph sounds such as ship, shop, and shell for /sh/
- Listen for digraphs at the beginning or end of words such as chat and bath

Decode and encode digraph, double ending, and blend words.

- Read words such as swim, truck, shell, and frog by tapping each sound and blending the word together
- Say words such as black, spot, and chess aloud, tap the sounds heard, and write each sound in the word

Decode skill-based sentences.

- Read sentences such as "The kids chat." and "She can flush it." while pointing to each word
- Reread sentences such as "The bell fell." and "He has a red rash." to build fluency and confidence

Decode and comprehend passages.

- Read short passages and talk about the characters, setting, and main story events
- Ask questions such as "What was the problem?" and "How was it solved?" after reading the passage



UNIT 4

Assessment



Name: _____

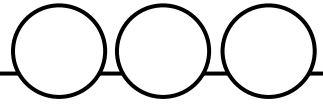
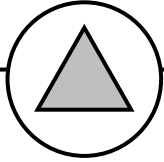

Student Goal: I can identify the long vowel sounds.

Instructions: Identify the matching long vowel sound.

ā	ī	ō	ā	ī	ō	ā	ī	ō	ā	ī	ō	ā	ī	ō
ū	ē		ū	ē		ū	ē		ū	ē		ū	ē	

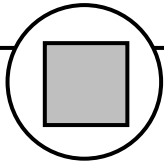

Student Goal: I can decode CVCE words without context.

Instructions: Identify the matching CVCE word.

cute	fume	mule	wipe	pine	like	gave	rate	cave	dove	rose	hose
fuse	dune	dude	pike	line	pipe	gate	game	late	note	nose	home

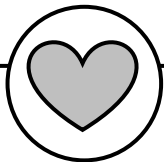

Student Goal: I can encode CVCE words sound-by-sound.

Instructions: Identify the matching sounds in each word.

m	o	ve	m	o	me	m	u	se	d	u	ke
r	i	be	d	a	ve	c	a	de	c	a	me
d	a	ke	f	i	de	v	o	te	t	i	ne

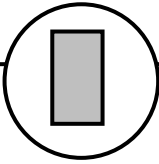

Student Goal: I can decode simple context.
Instructions: Identify the matching image.

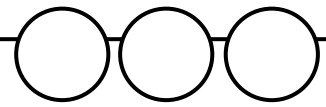

He is on a hike.		This is my home.		They will race.		Did you mute it?	

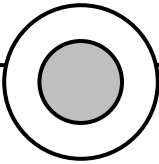

Student Goal: I can decode skill-based words in context.
Instructions: Identify the matching sentence.

They got a game.	He is not five.	The dune is hot.	We rode the ride.
The wave is big.	This is my bike.	That tot is so cute.	What mole did it?
She is so late.	We will dive.	A pet mule is fun.	That is a cone.



Student Goal: I can encode CVCE words sound-by-sound.
Instructions: Write the matching word sound-by-sound.



Student-Facing Mat

ě	ū	ō	ĩ	ā	ǔ	ē	ǒ	ī	ǎ
---	---	---	---	---	---	---	---	---	---

came	take	cake	make	made	gave	
ate	late	name	like	ride	five	
white	those	use	these	place	why	
by	my					

her	were	once	upon	little	have
love	give	live	come	some	done
none	now	how			

Student-Facing Mat

Chase came to the lake with a big case.
 “Chase, what is in your case?” said Nate.
 “This case has my flute in it,” said Chase.
 “Can you play us a tune with your flute?”
 said Jane with a nice smile. Chase did
 open the case, but the flute was not in it.
 Chase made a sad face and said, “I did
 not get the flute back in the case so I
 cannot play it.” Jane said, “It is ok, Chase!”

Listen and Answer: Who are the characters in the story?

Nate

Dale

Jane

Chase

What is the setting of the story?

cave

zone

dune

lake

What is the problem in the story?

Chase got
sick at the
lake.

Chase did
not have
his flute.

A big
snake bit
Nate.

Jane was
late to the
lake.



Implementation Guide

Bonus built-in mapping dots for students.

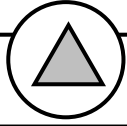

Read aloud the picture name for students. Differentiation tip: Before completing this section, have students chorally generate the vowel sound for each letter.

Put your finger on the triangle. Listen, **vine**. Find the matching vowel sound in **vine**.

Listen, **cake**. Find the matching vowel sound in **cake**.

Listen, **rose**. Find the matching vowel sound in **rose**.

Listen, **cube**. Find the matching vowel sound in **cube**.

Listen, **mice**. Find the matching vowel sound in **mice**.

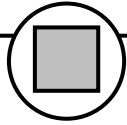

Read aloud the picture name for students. Implementation tip: Draw a rake on the board. Write the words rake and cake. Have students decode both before choosing.

Put your finger on the square. Listen, **fume**. Find the matching word for **fume**.

Listen, **pipe**. Find the matching word for **pipe**.

Listen, **gate**. Find the matching word for **gate**.

Listen, **nose**. Find the matching word for **nose**.

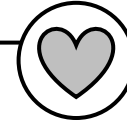

Read aloud the picture name for students. Implementation tip: Draw a kite on the board. Encourage students to encode the word sound-by-sound.

Put your finger on the heart. Listen, **robe**. Identify the beginning, middle, and ending sounds in **robe**.

Listen, **five**. Identify the beginning, middle, and ending sounds in **five**.

Listen, **vase**. Identify the beginning, middle, and ending sounds in **vase**.

Listen, **dune**. Identify the beginning, middle, and ending sounds in **dune**.

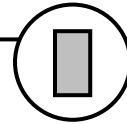

Students will decode the sentence and choose the matching picture. If needed, you may read the picture names if the student does not have the vocabulary knowledge.

Put your finger on the rectangle. Decode each sentence and choose the matching image.

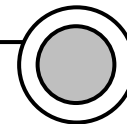

Read aloud the picture name for students. Implementation tip: Draw a cane on the board. Write "I see a cane." and "I have a cape." Have students blend through both.

Put your finger on the circle. Listen, **game**. Find the matching sentence for **game**.

Listen, **bike**. Find the matching sentence for **bike**.

Listen, **mule**. Find the matching sentence for **mule**.

Listen, **rode**. Find the matching sentence for **rode**.

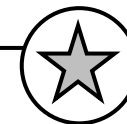

Read aloud the picture name for students. Implementation tip: Draw a pole on the board. Encourage students to encode the word sound-by-sound.

Put your finger on the star. Listen, **hive**. Write the word **hive**.

Listen, **bone**. Write the word **bone**.

Listen, **tape**. Write the word **tape**.

Listen, **tube**. Write the word **tube**.



Implementation Guide

ě	ū	ō	ǐ	ā	ǔ	ē	ö	ī	ǎ
---	---	---	---	---	---	---	---	---	---

Students will demonstrate long and short sounds knowledge.

Put your finger on the first sound. State the long or short sound. Continue to go through the vowels and state the matching sound. If you do not know the sound, tap the table and move to the next vowel.

came	take	cake	make	made	gave
ate	late	name	like	ride	five
white	those	use	these	place	why
by	my				

Students will display their ability to decode CVCE words. These are high frequency words. However, these words are decodable, and students are allowed/encouraged to decode the words sound-by-sound if needed.

Put your finger on the first word. Read the word. If needed, stretch the word sound-by-sound.

her	were	once	upon	little	have
love	give	live	come	some	done
none	now	how			

Students will demonstrate irregular word knowledge.

These are irregular words. They will contain irregular or heart sounds that you cannot fully decode. These are words you likely can tell me by sight. Put your finger on the first word. State the word.

Chase came to the lake with a big case. "Chase, what is in your case?" said Nate. "This case has my flute in it," said Chase. "Can you play us a tune with your flute?" said Jane with a nice smile. Chase did open the case, but the flute was not in it. Chase made a sad face and said, "I did not get the flute back in the case so I cannot play it." Jane said, "It is ok, Chase!"

Students will display their ability to decode a complex CVCE words passage. After reading, students will be asked to display their reading comprehension of the passage.

Read the passage to discover the characters, setting, and problem of the story.

Students will identify the comprehension story elements from the passage.

Characters (**Chase, Nate, Jane**)

Setting (**lake**)

Problem (**Chase did not have his flute.**)



Assessment Overview

Student Name:	Grade Level:
---------------	--------------

Goal	Notes
<p>Identify long and short vowel sounds. ă ū ō ĭ ā ŭ ē ǒ ī ă</p>	
<p>Decode CVCE words. came take cake make made gave ate late name like ride five white those use these place why by my</p>	
<p>Identify irregular words. her were once upon little have love give live come some done none now how</p>	
<p>Identify long vowel sounds. ī ā ō ū ī</p>	
<p>Decode and encode CVCE words. fume pipe gate nose robe five vase dune hive tape bone tube</p>	
<p>Decode CVCE sentences. He is on a hike. This is my home. They will race. Did you mute it? They got a game. This is my bike. A pet mule is fun. We rode the ride.</p>	
<p>Decode a complex CVCE passage and answer comprehension questions for story elements - characters, setting, and problem/solution.</p>	

Overall Notes:

Phonics Skills At-Home Support Guide

This guide provides simple ways to support your child's early reading and CVCE phonics skills at home. The activities are designed to be quick, hands-on, and easy to use with everyday materials. Practicing these skills regularly will help build confidence, strengthen decoding skills, and support their success.

Identify long and short vowel sounds.

- Practice saying long and short vowel sounds such as tap and tape
- Listen for vowel sounds in words and identify if the vowel is long or short

Decode CVCE words.

- Tap and blend CVCE words such as cake and tube while reading aloud
- Read CVCE words such as came, ride, nose, and mule and notice the silent e at the end of the word

Identify irregular words.

- Practice reading irregular words commonly found in sentences such as once, love, some, and were
- Find irregular words while reading simple CVCE books together

Identify long vowel sounds.

- Sort CVCE words by long vowel sounds such as cake and tape for long a
- Stretch CVCE words aloud to hear the long vowel sound in words such as hive, bone, and cube

Decode and encode CVCE words.

- Read words such as pipe, gate, and dune by tapping each sound and blending the word together
- Say words such as robe, five, and vase aloud, tap the sounds heard, and write each sound in the word

Decode CVCE sentences.

- Read sentences such as "He is on a hike." and "This is my bike." while pointing to each word
- Reread sentences such as "They got a game." and "We rode the ride." to build fluency and confidence

Decode and comprehend CVCE passages.

- Read short CVCE passages and talk about the characters, setting, and main story events
- Ask questions such as "What was the problem?" and "How was it solved?" after reading the passage



UNIT 5

Assessment



Name: _____

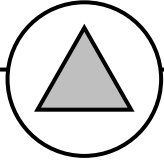

Student Goal: I can identify the sounds.

Instructions: Identify the matching sound.

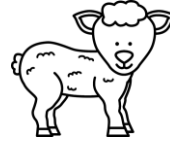

ar	ir	or	ar	er	or	ar	ur	or	ar	ir	or	ar	er	or
kn	wr	mb	kn	wr	mb	kn	wr	mb	kn	wr	mb	kn	wr	mb

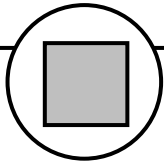

Student Goal: I can decode skill-based words without context.

Instructions: Identify the matching skill-based word.



curb	turn	spurt	swirl	whirl	smirk	wrap	wreck	wren	knoll	knelt	knit
blurb	turbo	surf	skirt	bird	dirt	write	wrist	writ	knife	knob	knot

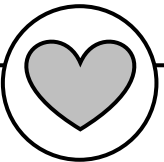

Student Goal: I can encode skill-based words sound-by-sound.

Instructions: Identify the matching sounds in each word.

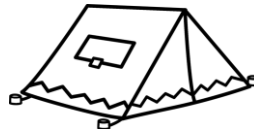

y	or	n	c	ar	ch	t	e	s	d	m	a	l	t
f	ar	k	p	er	t	d	i	n	t	r	i	f	d
b	ur	d	d	ir	d	s	o	f	k	p	o	n	k

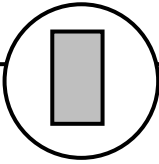

Student Goal: I can decode simple context.
Instructions: Identify the matching image.

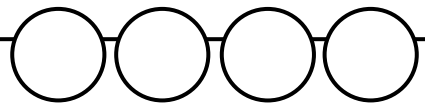

A nest is here.		Look at the wind.		This is the park.		He will just knock.	

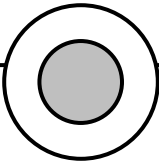

Student Goal: I can decode skill-based words in context.
Instructions: Identify the matching sentence.

A crab likes kelp.	Brad has a cast.	Will she slurp it?	Was it a wreck?
He will help him.	That is his belt.	That is a curb.	We can wrap it.
They have a gift.	Look at the milk.	Did you store it?	This is my wrist.



Student Goal: I can encode skill-based words sound-by-sound.
Instructions: Write the matching word sound-by-sound.

-----	-----	-----	-----



Student-Facing Mat

ir	er	ar	or	ur	kn	wr	mb
----	----	----	----	----	----	----	----

left	help	milk	land	jump	went
ask	best	fast	just	last	must
next	small	call	fall	pull	full
think	thank	bring	king	long	song
start	far	part	after	under	over
better	first	hurt	four	before	write

would	could	should	find	kind	want
along	warm	work	word	world	other
mother	water	sure	picture	where	there
their	they're	know	knew		

Student-Facing Mat

Mark had a big chest that was in his yard by the elm. "What is in your chest, Mark?" said Fern. Mark began to pull a box from the chest. There was a picture of a troll. "Why do you have a troll picture?" said Fern. Mark said, "This troll was a gift from my pal, Phil. I lost the troll and could not find it. My mom gave me this picture of the troll so I could remember it."

Listen and Answer: Who are the characters in the story?

Mark	Brent	Barb	Fern
------	-------	------	------

What is the setting of the story?

camp	yard	park	gulf
------	------	------	------

What is the problem in the story?

Fern had the troll.	Mark lost his troll.	Fern lost her troll.	Mom lost the troll.
---------------------	----------------------	----------------------	---------------------



Implementation Guide

Bonus built-in mapping dots for students.

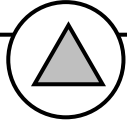

Read aloud the picture name for students. Differentiation tip: Before completing this section, have students chorally generate the sound for each grapheme.

Put your finger on the triangle. Listen, **skirt**. Find the matching sound in **skirt**.

Listen, **corn**. Find the matching sound in **corn**.

Listen, **knob**. Find the matching sound in **knob**.

Listen, **lamb**. Find the matching sound in **lamb**.

Listen, **barn**. Find the matching sound in **barn**.

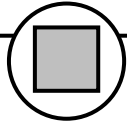

Read aloud the picture name for students. Implementation tip: Draw a ramp on the board. Write the words damp and ramp. Have students decode both before choosing.

Put your finger on the square. Listen, **surf**. Find the matching word for **surf**.

Listen, **bird**. Find the matching word for **bird**.

Listen, **wrap**. Find the matching word for **wrap**.

Listen, **knit**. Find the matching word for **knit**.

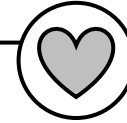

Read aloud the picture name for students. Implementation tip: Draw a cord on the board. Encourage students to encode the word sound-by-sound.

Put your finger on the heart. Listen, **fork**. Identify the sounds in **fork**.

Listen, **card**. Identify the sounds in **card**.

Listen, **tent**. Identify the sounds in **tent**.

Listen, **raft**. Identify the sounds in **raft**.

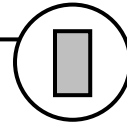

Students will decode the sentence and choose the matching picture. If needed, you may read the picture names if the student does not have the vocabulary knowledge.

Put your finger on the rectangle. Decode each sentence and choose the matching image.

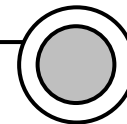

Read aloud the picture name for students. Implementation tip: Draw a yard on the board. Write "I see a yard." and "I see yarn." Have students blend through both.

Put your finger on the circle. Listen, **help**. Find the matching sentence for **help**.

Listen, **belt**. Find the matching sentence for **belt**.

Listen, **slurp**. Find the matching sentence for **slurp**.

Listen, **wrist**. Find the matching sentence for **wrist**.

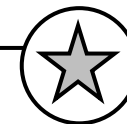

Read aloud the picture name for students. Implementation tip: Draw a mask on the board. Encourage students to encode the word sound-by-sound.

Put your finger on the star. Listen, **ramp**. Write the word **ramp**.

Listen, **comb**. Write the word **comb**.

Listen, **star**. Write the word **star**.

Listen, **knife**. Write the word **knife**.



Implementation Guide

ir	er	ar	or	ur	kn	wr	mb
----	----	----	----	----	----	----	----

Students will demonstrate r-control and silent letters sound knowledge.

Put your finger on the first sound. State the sound. Continue to go through the sounds one-by-one. If you do not know the sound, tap the table and move to the next sound.

left	help	milk	land	jump	went
ask	best	fast	just	last	must
next	small	call	fall	pull	full
think	thank	bring	king	long	song
start	far	part	after	under	over
better	first	hurt	four	before	write

Students will display their ability to decode skill-based words. These are high frequency words. However, these words are decodable, and students are allowed/encouraged to decode the words sound-by-sound if needed.

Put your finger on the first word. Read the word. If needed, stretch the word sound-by sound.

would	could	should	find	kind	want
along	warm	work	word	world	other
mother	water	sure	picture	where	there
their	they're	know	knew		

Students will demonstrate irregular word knowledge.

These are irregular words. They will contain irregular or heart sounds that you cannot fully decode. These are words you likely can tell me by sight. Put your finger on the first word. State the word.

Mark had a big chest that was in his yard by the elm. "What is in your chest, Mark?" said Fern. Mark began to pull a box from the chest. There was a picture of a troll. "Why do you have a troll picture?" said Fern. Mark said, "This troll was a gift from my pal, Phil. I lost the troll and could not find it. My mom gave me this picture of the troll so I could remember it."

Students will display their ability to decode a complex skill-based passage. After reading, students will be asked to display their reading comprehension of the passage.

Read the passage to discover the characters, setting, and problem of the story.

Students will identify the comprehension story elements from the passage.

Characters **(Mark and Fern)**
 Setting **(yard)**
 Problem **(Mark lost his troll.)**



Assessment Overview

Student Name:	Grade Level:
Goal	Notes
Identify sounds in isolation. ir er ar or ur kn wr mb	
Decode skill-based words. left help milk land jump went ask best fast just last must next small call fall pull full think thank bring king long song start far part after under over better first hurt four before write	
Identify irregular words. would could should find kind want along warm work word world other mother water sure picture where there their they're know knew	
Identify sounds in words. ir or kn mb ar	
Decode and encode words. surf bird wrap knit fork card tent raft ramp star comb knife	
Decode skill-based sentences. A nest is here. Look at the wind. This is the park. He will just knock. He will help him. That is his belt. Will she slurp it? This is my wrist.	
Decode a complex ending blend and r-controlled words passage and answer comprehension questions for story elements - characters, setting, and problem/solution.	

Overall Notes:

Phonics Skills At-Home Support Guide

This guide provides simple ways to support your child's early reading and r-controlled vowel, CVCC, and silent letter phonics skills at home. The activities are designed to be quick, hands-on, and easy to use with everyday materials. Practicing these skills regularly will help build confidence, strengthen decoding skills, and support their success.

Identify sounds in isolation.

- Practice saying sounds such as /ir/, /er/, /ar/, /or/, and /ur/
- Practice reading silent letter patterns such as kn, wr, and mb in words such as knife, write, and comb

Decode skill-based words.

- Tap and blend words such as drift, land, jump, and think while reading
- Read r-controlled and CVCC words such as star, hurt, sift, and desk

Identify irregular words.

- Practice reading irregular words found in sentences such as would, could, their, and know
- Find irregular words while reading skill-based books together

Identify sounds in words.

- Listen for r-controlled vowel sounds in words such as bird, fork, and surf
- Listen for silent letter patterns in words such as wrap, comb, and knit

Decode and encode words.

- Read words such as raft, ramp, bird, and tent by tapping each sound and blending the word together
- Say words such as fork, star, and knife aloud, tap the sounds heard, and write each sound in the word

Decode skill-based sentences.

- Read sentences such as "A nest is here." and "This is the park." while pointing to each word
- Reread sentences such as "He will just knock." and "This is my wrist." to build fluency and confidence

Decode and comprehend passages.

- Read short passages and talk about the characters, setting, and main story events
- Ask questions such as "What was the problem?" and "How was it solved?" after reading the passage



UNIT 6

Assessment



Name: _____

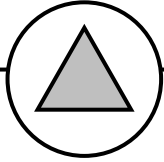

Student Goal: I can identify the vowel variant.

Instructions: Identify the matching vowel variant sound.

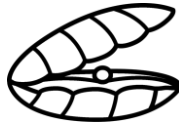

ai	ay	oa	ai	ay	oa	ai	ay	oa	ai	ay	oa	ai	ay	oa
ee	ie	oy	ee	ie	oy	ee	ie	oy	ee	ie	oy	ee	ie	oy

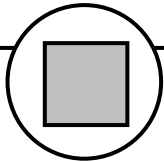

Student Goal: I can decode vowel variant words without context.

Instructions: Identify the matching skill-based word.

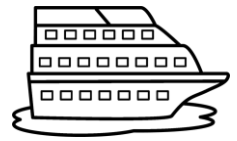
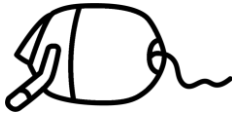

weed	heel	beet	load	boat	toad	might	night	sight	suit	fruit	juice
feel	reel	bee	goat	road	loaf	light	right	fight	cruise	news	bruise

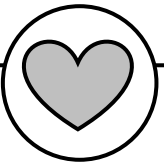

Student Goal: I can encode vowel variant words sound-by-sound.

Instructions: Identify the matching sounds in each word.

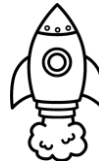
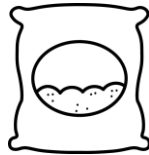
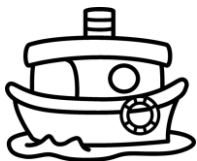

g	ow	p	f	oi	d	p	aw	n	e	b	t	ai	k
b	oa	t	b	oy	l	t	au	s	ch	c	r	ea	m
s	oe	d	s	oo	t	l	a	m	p	s	l	ay	n

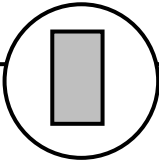

Student Goal: I can decode simple context.
Instructions: Identify the matching image.

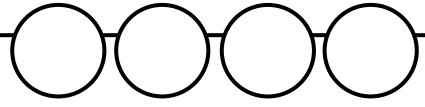

She will take the tray.		We will eat some honey.		She will use a float to swim.		Dad got a new suit today.	

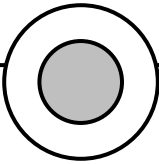

Student Goal: I can decode vowel variant words in context.
Instructions: Identify the matching sentence.

The leaf did fall.	What is in the sky?	We are in town.	Grab my boot.
That kid can lead.	That is yummy pie.	That is his brow.	Was it at noon?
That is lean meat.	He just cried.	This is my crown.	Put on your hood.



Student Goal: I can encode vowel variant words sound-by-sound.
Instructions: Write the matching word sound-by-sound.

-----	-----	-----	-----



Student-Facing Mat

ai	ay	oa	ee	ie	oy
----	----	----	----	----	----

day	may	way	say	away	great
break	eight	green	sleep	keep	feet
three	each	mean	eat	funny	city
read	clean	please	own	show	grow
follow	yellow	right	light	high	blue
draw	saw	boy	thought	bought	out
round	found	sound	down	brown	new
too	soon	good	put	push	

again	today	any	many	very	pretty
goes	does	our	been	around	about
above	whose	two			

Student-Facing Mat

Taylor works on a freight train. She is the driver. Taylor saw an issue with the train rail. “Jay, grab a nail. We need to fix this train rail,” said Taylor. Jay got the hammer and a nail. He hit the nail into the rail. “We are good to go now. We are off to our next city,” said Taylor. **All aboard!** The light went from red to green. The freight train was off as it went down the train tracks.

Listen and Answer: Who are the characters in the story?

Taylor	Joy	Jay	Drew
--------	-----	-----	------

What is the setting of the story?

beach	train shed	booth	train rail
-------	------------	-------	------------

What is the problem in the story?

Jay could not go to work.	The train got a new wheel.	The train rail was broken.	Taylor was too sick to drive.
---------------------------	----------------------------	----------------------------	-------------------------------



Implementation Guide

Bonus built-in mapping dots for students.

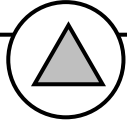

Read aloud the picture name for students. Differentiation tip: Before completing this section, have students chorally generate the vowel sound for each letter.

Put your finger on the triangle. Listen, **hay**. Find the matching vowel sound in **hay**.

Listen, **fries**. Find the matching vowel sound in **fries**.

Listen, **oyster**. Find the matching vowel sound in **oyster**.

Listen, **weed**. Find the matching vowel sound in **weed**.

Listen, **road**. Find the matching vowel sound in **road**.

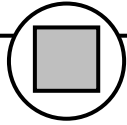

Read aloud the picture name for students. Implementation tip: Draw a coat on the board. Write the words coat and coal. Have students decode both before choosing.

Put your finger on the square. Listen, **reel**. Find the matching word for **reel**.

Listen, **toad**. Find the matching word for **toad**.

Listen, **night**. Find the matching word for **night**.

Listen, **cruise**. Find the matching word for **cruise**.

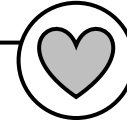

Read aloud the picture name for students. Implementation tip: Draw a sail on the board. Encourage students to encode the word sound-by-sound.

Put your finger on the heart. Listen, **boat**. Identify the beginning, middle, and ending sounds in **boat**.

Listen, **soil**. Identify the beginning, middle, and ending sounds in **soil**.

Listen, **launch**. Identify the beginning, middle, and ending sounds in **launch**.

Listen, **break**. Identify the beginning, middle, and ending sounds in **break**.

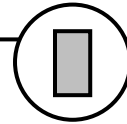

Students will decode the sentence and choose the matching picture. If needed, you may read the picture names if the student does not have the vocabulary knowledge.

Put your finger on the rectangle. Decode each sentence and choose the matching image.

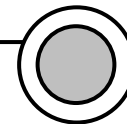

Read aloud the picture name for students. Implementation tip: Draw a snout on the board. Write "I see the scout." and "It is a snout." Have students blend through both.

Put your finger on the circle. Listen, **leaf**. Find the matching sentence for **leaf**.

Listen, **pie**. Find the matching sentence for **pie**.

Listen, **crown**. Find the matching sentence for **crown**.

Listen, **boot**. Find the matching sentence for **boot**.

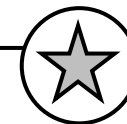

Read aloud the picture name for students. Implementation tip: Draw a pail on the board. Encourage students to encode the word sound-by-sound.

Put your finger on the star. Listen, **rain**. Write the word **rain**.

Listen, **goat**. Write the word **goat**.

Listen, **sheep**. Write the word **sheep**.

Listen, **saw**. Write the word **saw**.



Implementation Guide

ai

ay

oa

ee

ie

oy

Students will demonstrate vowel variant sound knowledge.

Put your finger on the first vowel variant. State the sound. Continue to go through the vowel variants and state the matching sound. If you do not know the sound, tap the table and move to the next vowel variant.

day	may	way	say	away	great
-----	-----	-----	-----	------	-------

break	eight	green	sleep	keep	feet
-------	-------	-------	-------	------	------

three	each	mean	eat	funny	city
-------	------	------	-----	-------	------

read	clean	please	own	show	grow
------	-------	--------	-----	------	------

follow	yellow	right	light	high	blue
--------	--------	-------	-------	------	------

draw	saw	boy	thought	bought	out
------	-----	-----	---------	--------	-----

round	found	sound	down	brown	new
-------	-------	-------	------	-------	-----

too	soon	good	put	push	
-----	------	------	-----	------	--

Students will display their ability to decode skill-based words. These are high frequency words. However, these words are decodable, and students are allowed/encouraged to decode the words sound-by-sound if needed.

Put your finger on the first word. Read the word. If needed, stretch the word sound-by sound.

again	today	any	many	very	pretty
-------	-------	-----	------	------	--------

goes	does	our	been	around	about
------	------	-----	------	--------	-------

above	whose	two			
-------	-------	-----	--	--	--

Students will demonstrate irregular word knowledge.

These are irregular words. They will contain irregular or heart sounds that you cannot fully decode. These are words you likely can tell me by sight. Put your finger on the first word. State the word.

Taylor works on a freight train. She is the driver. Taylor saw an issue with the train rail. "Jay, grab a nail. We need to fix this train rail," said Taylor. Jay got the hammer and a nail. He hit the nail into the rail. "We are good to go now. We are off to our next city," said Taylor. **All aboard!** The light went from red to green. The freight train was off as it went down the train tracks.

Students will display their ability to decode a complex skill-based passage. After reading, students will be asked to display their reading comprehension of the passage.

Read the passage to discover the characters, setting, and problem of the story.

Students will identify the comprehension story elements from the passage.

Characters **(Taylor and Jay)**

Setting **(train rail)**

Problem **(The train rail was broken.)**



Assessment Overview

Student Name:	Grade Level:
Goal	Notes
Identify vowel variants. ai ay oa ee ie oy	
Decode skill-based words. day may way say away great break eight green sleep keep feet three each mean eat funny city read clean please own show grow follow yellow right light high blue draw saw boy thought bought out round found sound down brown new too soon good put push	
Identify irregular words. again today any many very pretty goes does our been around about above whose two	
Identify vowel variants in words. ai ay oa ee ie oy	
Decode and encode words. reel toad night cruise boat soil launch break rain sheep goat saw	
Decode skill-based sentences. She will take the tray. We will eat some honey. She will use a float to swim. Dad got a new suit today. The leaf did fall. That is yummy pie. This is my crown. Grab my boot.	
Decode a complex vowel variant passage and answer comprehension questions for story elements - characters, setting, and problem/solution.	

Overall Notes:

Phonics Skills At-Home Support Guide

This guide provides simple ways to support your child's early reading and vowel variant phonics skills at home. The activities are designed to be quick, hands-on, and easy to use with everyday materials. Practicing these skills regularly will help build confidence, strengthen decoding skills, and support your child's success as they continue learning to read.

Identify vowel variants.

- Practice saying vowel variant sounds such as ai, ay, oa, ee, ie, and oy
- Connect the vowel patterns to words such as rain, day, boat, pie, and toy

Decode skill-based words.

- Tap and blend words such as day, green, boat, and light while reading
- Read vowel variant words such as found, down, new, soon, and push and notice the vowel patterns in each word

Identify irregular words.

- Practice reading irregular words commonly found in sentences such as again, many, pretty, and does
- Find irregular words while reading vowel variant books together

Identify vowel variants in words.

- Sort words by vowel pattern such as rain, wait, and sail for ai
- Listen for vowel variant sounds in words such as goat, night, cruise, and saw

Decode and encode words.

- Read words such as reel, toad, night, and boat by tapping each sound and blending the word together
- Say words such as rain, sheep, goat, and saw aloud, tap the sounds heard, and write the vowel pattern in the word

Decode skill-based sentences.

- Read sentences such as "She will take the tray." and "We will eat some honey." while pointing to each word
- Reread sentences such as "The leaf did fall." and "Grab my boot." to build fluency and confidence

Decode and comprehend vowel variant passages.

- Read short passages and talk about the characters, setting, and main story events
- Ask questions such as "What was the problem?" and "How was it solved?" after reading the passage



Guided Phonics + Beyond

Guided Phonics + Beyond is the property of Tara West and is protected through copyright and trademark registrations. All rights reserved.

No part of this digital download may be reproduced electronically, shared without additional licenses, or placed on the internet for others to access without the prior permission from the publisher, Tara West.

If you are a school district using this download as curriculum for more than one teacher an additional school license will need to be purchased.

Fonts used within this download are intellectual property of Kimberly Geswein and Print Designs by Kris.

The clipart images are intellectual property of [Laura Strickland of Whimsy Clips](#) and [Bunny on a Cloud](#).

Contact Information

Email: littlemindsatworkLLC@gmail.com

Website: www.littlemindsatwork.org

Store: <http://www.teacherspayteachers.com/Store/Tara-West>